

NEW
ENHANCED

STERLING

Superior window
balancing

STERLING

HEAVY DUTY
FRICTION HINGES FOR
COMMERCIAL
APPLICATIONS

- Self-balancing hinge
- Capable of achieving all leading international standards, including the UK BS 6375; the North American AAMA 904.1; and the Singapore Standard 212:2004
- Unrivalled weather sealing
- Austenitic stainless steel for enhanced corrosion resistance
- Superior Carrying Capacity
- 12 year guarantee (details available upon request)

High performance components are used throughout Securistyle's hinge range. This investment results in a reliability of operation which is unequalled in the industry. Sterling has been proven up to 30,000 full cycles and conforms to all leading international standards.

Full technical and sales support which will cover consultancy per project basis and on-site advice when necessary.



◀ **NEW REDESIGNED END POINT & VENT ARM**

Gust load resistance improved via redesigned end point and vent arm. Testing at ATi (USA) reported increased gust load resistance <135psf/6470pa.



▲ **NEW DIE CAST ZINC ALLOY PIVOT BLOCK**

Pivot block locates and supports 3rd link pivot providing increased bearing surface reducing vent drop throughout products guaranteed 30,000 cycles.



◀ **PULL IN BLOCK**

Maintains effective weather seal and reduces bowing on large vents.

STERLING

Product Specification

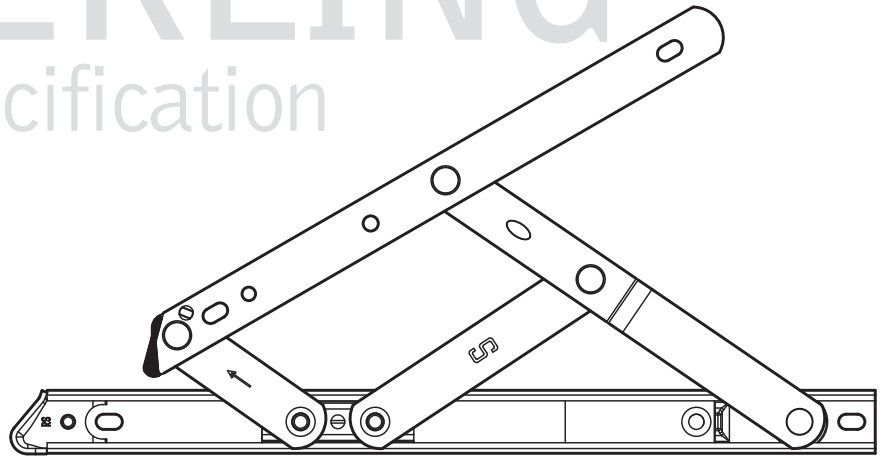

PRODUCT SPECIFICATION

- Anti-rubbing composite slider eliminates metal to metal contact and helps prevent vent drop
- Carries commercial vents from 0.3m to 2.5m high, up to 180kg in weight
- Adjustable opening stop on top hung hinges
- Available in 10" to 26" top hung and 10" & 16" side hung
- 10" and 16" side hung open beyond 80° for easy cleaning of windows
- The SPTH16 has been designed to specifically meet the growing trend for low height extra wide heavy windows.

OPTIONAL FEATURES

- Add on adjustment device

Note: As with all types of friction hinges, friction can not be provided until the slider moves, therefore when limiting the opening of top hung vents to angles of 10° or less, additional device(s) will be required to enable them to remain in a selected ventilation position.

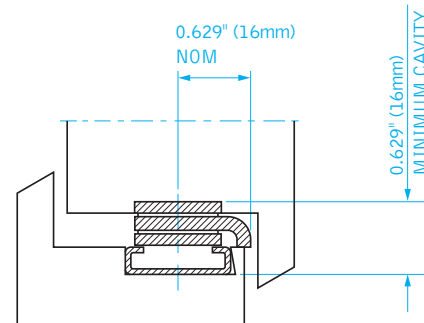
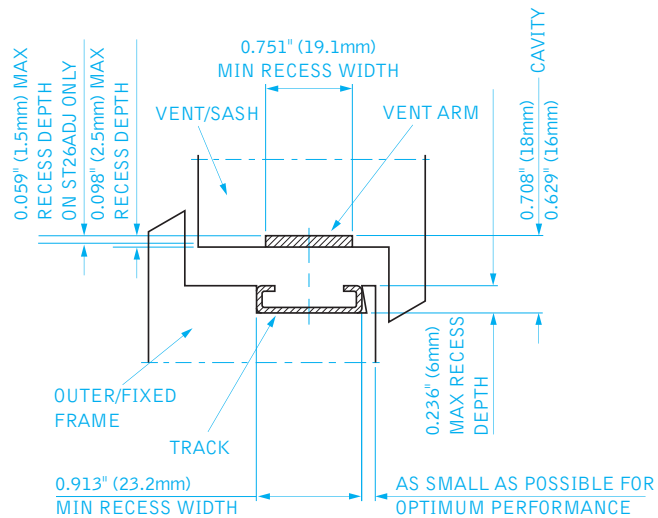

NOTE ADDITIONAL LINK FORM ON SPTH16 AND SPT22W AND SPT26.

STERLING

Hinge Code	Hinge Length (in/mm)	Max Vent Weight (lb/Kg)	Max Vent Height (in/mm)	Min Vent Height (in/mm)	Opening Angle (+/- 2.5°)	Number of cycles ('000's)
SPT10	10/262	88/40	25.0/640	10.5/267	50°	30
SPT12	12/313	110/50	31.5/800	25.2/640	50°	30
SPT16/W	16/415	143/65	43.3/1100	31.5/800	50°	30
SPTH16*	16/415	220/100	43.3/1100	23.6/600	30°	30
SPT22*	22/567	220/100	59.0/1500	42.9/1090	45°	30
SPT22W*	22/567	220/100	78.7/2000	59.0/1500	20°	30
SPT26*	26/680	397/180	98.4/2500	78.7/2000	20°	30
Side Hung			Max Vent Width	Min Vent Width		
SPS10	10/262	83/38	26.0/660	11.8/300	85°	30
SPS16	16/415	103/47	33.0/838	17.7/450	90°	30

*Vents of 100kg must be fitted with S7280 cam adjustment devices, which are optional on lighter vents.

Separate restrictors (SR8 or SR16BAC pair), vent holding devices or an operating mechanism may be required to hold large vents in a selected ventilation position against variable wind pressure.



Due to our policy of continual improvement we reserve the right to alter specifications without notice. It is the responsibility of the window manufacturer to ensure that the finished window meets the required performance and safety specification.

All transactions are subject to our standard conditions of supply, which are available on request.